



# **GASBOY**

---

**MODELS 617 AND 620**

**HIGH SPEED PUMPS**

**INSTALLATION/OPERATION/PARTS**

**MANUAL**

**035211**

**REV. 03/07/03**

**INSTALLERS - IMPORTANT**

**In addition to installation information, this manual contains warnings, safeguards and procedures on the use and care of the Series 617 and 620 pump. Please leave this manual with the pump owner after the installation is complete.**

Copyright 2003 by Gasboy International LLC All rights reserved.  
The information in this document is confidential and proprietary. No further disclosure shall be made without permission from Gasboy International LLC Gasboy International LLC believes that the information in this document is accurate and reliable. However, we assume no responsibility for its use, nor for any infringements of patents or other rights of third parties resulting from its use. We reserve the right to make changes at any time without notice.

**GASBOY INTERNATIONAL LLC LANSDALE, PA**

# IMPORTANT WARNINGS AND SAFEGUARDS

Gasoline and petroleum products are flammable. To avoid injury or death to persons or damage to equipment or property, follow these listed warnings and other warnings and precautions outlined in this manual when installing, using, or working around this equipment. Check with GASBOY Technical Services for compatibility of liquids with pump materials.

## TURN OFF AND LOCK OUT ALL POWER TO PUMP BEFORE PERFORMING SERVICE, MAINTENANCE OR IN THE EVENT OF A FUEL SPILL.

All products must be installed by a qualified installer and used in conformance with all building, fire, and environmental codes and other safety requirements applicable to its installation and use, including, but not limited to, NFPA 30, NFPA 30A, NFPA 395 & NFPA 70. A qualified installer is familiar with fuel systems installations under the above stated building, fire, and environmental codes and other safety requirements for the particular type of installation.

This product is only part of a fuel dispensing system and additional equipment and accessories, such as, but not limited to, breakaway connectors, shear valves, pressure regulators, flow limiters, and other safety devices may be necessary to meet the applicable codes.

For maximum safety, we recommend that all employees be trained as to the location and procedure for turning off power to the entire system. Instructions regarding proper operation of the equipment along with the appropriate safety warnings should be posted in plain view at the fuel island.

Before performing service or maintenance (including changing of fuel filters or strainers) or in the event of a fuel spill, turn off and lock out all power to the system. In battery-powered pumps, disconnect power source. In submersible pump applications, turn off and lock out power at the master panel and close any impact valves to the submersible pump and any other dispensers which use that submersible pump. AC power can feed back into a shut-off dispenser when dispensers share a common submersible pump or starter relay. Also block islands so no vehicles can pull up to the dispenser when the dispenser is being worked on.

**DO NOT** use Teflon tape for any pipe threads in the product.

**DO NOT** use consumer pumps for pumping fuel or additives into aircraft.

**DO NOT** use commercial pumps for direct fueling of aircraft without filters and separators necessary to ensure product purity.

**DO NOT** use where sanitary design is required (for food products for human consumption) or with water-based liquids.

**DO NOT** smoke near the pump or when using the pump.

**DO NOT** use near open flame or electrical equipment which may ignite fumes.

**DO NOT** permit the dispensing of gasoline or other petroleum products into a vehicle with its motor running.

**DO NOT** permit the dispensing of gasoline or other petroleum products into unapproved containers or into approved containers in or on vehicles including trucks. All containers must be filled on the ground to prevent static discharge. Always use Approved and Listed hoses and nozzles with electric pumps and dispensers.

**DO NOT** block open the nozzle in any manner. Nozzles shall conform to UL and NFPA code requirements for attended or unattended service.

**DO** ensure that the pump is equipped with proper filters based on the product being dispensed and its intended use.

**DO** wear safety goggles and protective clothes when dispensing any liquid which may be potentially harmful or hazardous.

**DO** keep all parts of body and loose clothing clear of belts, pulleys, and other exposed moving parts at all times.

**DO** require washing and changing of clothes if fuel is spilled on a person or his/her clothing. Keep away from open flames, sparks, or people smoking.

**DO** provide a receptacle for catching product from pump/meter when servicing.

**DO** clean up product spills on the driveway. Turn off and lock out all power prior to cleanup.

**DO** insure pump is properly grounded.

**DO** insure hose is compatible with fluid being dispensed.

**DO** inspect hose, nozzle, and pump on a regular basis for wear, damage, or other conditions which may create a safety or environmental hazard.

**DO** make sure all pipe threads are properly cut and the inside reamed to remove burrs. Use UL classified gasoline-resisting compound on all joints of gasoline handling piping. Sealing compound must also be resistant to Gasohol (Ethanol and Methanol). Use gasoline-resistant pipe compound on male threads only; pipe compound used on female threads can be squeezed into the supply line where it can enter the product stream and become lodged in the pump or meter.

**DO** ensure that junction box covers are in place and properly tightened. Mating surfaces between the box and cover must be free of dirt, nicks, and scratches. All unused entries into the junction box must be properly plugged.

---

# CONTENTS

---

<b>Section 1:</b>	<b>OVERVIEW</b>	
	General .....	1-1
	Basic Features .....	1-1
	Options.....	1-1
<b>Section 2:</b>	<b>INSTALLATION, WIRING, AND OPERATION</b>	
	Installation Precautions .....	2-1
	Installation Guidelines .....	2-2
	Wiring .....	2-2
	Operation .....	2-4
	Start Motor .....	2-4
	Stop Motor .....	2-4
<b>Section 3:</b>	<b>MAINTENANCE AND TROUBLESHOOTING</b>	
	Disassembly of Motor.....	3-1
	Disassembly of Pump.....	3-1
	Troubleshooting Chart.....	3-3
<b>Section 4:</b>	<b>PARTS</b>	
	General Assembly .....	4-2
	Pump and Motor Assembly .....	4-4
	General Assembly, Exterior.....	4-6
	Options .....	4-7



## Section 1

---

# OVERVIEW

---

## GENERAL

The GASBOY Models 617 and 620 are high speed 24VDC and 12VDC pumps designed for use on vehicle-mounted tanks using the vehicle's 12VDC or 24VDC electrical system as a power supply.

### Basic Features

- 1" hose, 12' long
- Manual self-closing nozzle
- Supports gasoline, diesel, or kerosene
- Flow rate of up to 20 US GPM, 16 Imperial GPM, 76 liters (LPM)
- 5-vane, direct-drive, self-priming, rotary pump
- 1/4 HP, 2500 RPM motor, permanent magnet
- Current draw, running: 620: 45 Amps; 617: 30 Amps
- Check valve, located in base casting. No other line, foot, or check valve is required.
- Piston-type bypass reduces motor load
- 30-mesh cylindrical strainer, standard
- Maximum working pressure, 50 psi
- Connections: 2" NPT male thread for mounting on tank; 1" NPT female thread for suction.
- Finish, baked red urethane
- Weight: 38 lbs.

### Options

- Meter, Model 3460-4J (customer-installed)
- Automatic nozzle: shuts off at full tank

### USER NOTE

*The use of Gasboy Models 617 and 620 High Speed 12-volt and 24-volt pumps is similar to any other battery-operated piece of equipment. Typical auto and truck batteries will operate this unit. Extended pumping use without recharging batteries, or weak or run-down batteries may result in difficulty restarting the vehicle.*



---

## INSTALLATION, WIRING, AND OPERATION

---

### INSTALLATION PRECAUTIONS

All tanks and installations must conform with all building/fire codes, all Federal, State, and Local codes, National Electrical Code, (NFPA 70), NFPA 30, Automotive and Marine Service Station Code (NFPA 30A) and NFPA 395 codes and regulations.

Plan your installation carefully. Dispensing troubles, which seem to be pump-related, are frequently traced to faulty installation. Review the following list of installation **DO's** and **DON'T's** to avoid potential problems:

1. **DO** read the **WARNINGS** page at the front of this manual, preceding the Table of Contents. It contains important information regarding the safe use of your pumps.
2. **DO** install an emergency power cutoff, if the pump is used for other than personal use. In addition to circuit breaker requirements of NFPA 70 and NFPA 30A, a single control which simultaneously removes AC power from all site dispensing equipment is recommended. This control must be readily accessible, clearly labeled, and in accordance with all local codes. In order to provide the highest level of safety, we recommend that all employees be trained as to the location and procedure for turning off power to the dispensing equipment.
3. **DO** use breakaway couplings on discharge hose. While not required for tanks under 1100 gallons, use is recommended for safety reasons.
4. **DO** have the pump installed by a competent installer/electrician.
5. **DO NOT** experiment with a pump if you are not sure the installation is correct.
6. **DO NOT** overload sub- or main breaker panels.
7. **DO NOT** install any underground piping without proper swing joints. (Always use shoulder nipples, never close nipples).
8. **DO NOT** cover any lines until they have been both air- and liquid-tested.
9. **DO NOT** back-fill the tank or supply line with cinders or ashes. (Back-fill with clean sand, crushed rock, or pea gravel).
10. **DO NOT** use black iron pipe or fittings for underground installations. (Use only new galvanized or fiberglass\* pipe and fittings). \*Install all fiberglass pipe and fittings according to manufacturer's specifications and requirements.
11. **DO NOT** use power line wiring of inadequate capacity. (Use gauge specified by the wiring diagram or wire chart provided in Section 3).
12. **DO NOT** use a circuit breaker of improper size. (See Section 3).
13. **DO NOT** install fill pipe to tank where it can be submerged with standing water.
14. **DO NOT** use the GASBOY fuel dispensing equipment to remove water ballast from the storage tank.
15. **DO NOT** use gaskets on covers of explosion-proof type boxes. The sealing compound found around wires at various locations within conduit is a requirement of the National Electrical Code and should not be disturbed. Tighten junction box covers before replacing panels.

16. **DO NOT** use knock-out boxes or flexible conduit for installing this unit. All power and lighting wires should be run in threaded, rigid, metal conduit. All threaded connections must be drawn up tight with five (5) threads minimum engagement. Only one opening in the AC junction box is provided. At completion of the installation, it is the installer's responsibility to ensure that any unused openings are plugged.

## INSTALLATION GUIDELINES

All pumps are equipped with a 2" external and 1" internal threads. Suction tube is not provided. When installing suction tube, ensure that it is 3" from bottom of tank. Apply a coating of UL-approved petroleum gasoline-resistant pipe compound to the threads and suction tube before assembling. Tighten threaded joints securely.

Before beginning the installation, disconnect the battery cable that runs to the ground. This will prevent an electrical short or possible damage to the battery. Note the polarity of the terminal to which the ground cable is connected (- negative or + positive).

Be sure to properly ground the pump using a separate connection from the ground screw in the integral J-box to a good chassis ground.

**Be sure both the vehicle ignition switch and pump switch are off.** Route the power cable under the chassis to the engine compartment, mechanically securing the cable at various points to prevent damage to the power cord.

**NOTE: If the power cable supplied is not long enough, order a longer cable with the following specifications: 10 AWG, stranded three-conductor (one black, one white, one green) neoprene insulated, 600 volt rating.**

A 50 amp fuse or circuit breaker for 12VDC or 30 amp fuse or circuit breaker for 24VDC must be installed between the pump and the starter solenoid. This will protect the pump and battery from possible damage.

Do not use a temporary connection for providing connection to the battery.

Consult NFPA 30A, Table 7, for classification of areas around the pump and tank when determining location of J-box to be located outside of hazardous area.

## WIRING

The following diagrams show installation wiring and wiring for a negative and a positive ground system:

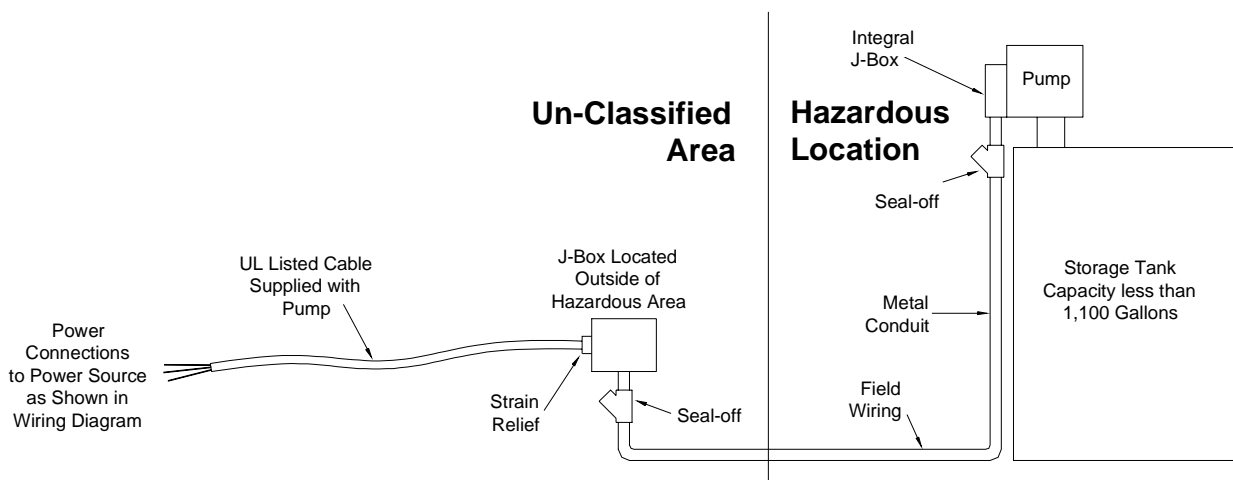

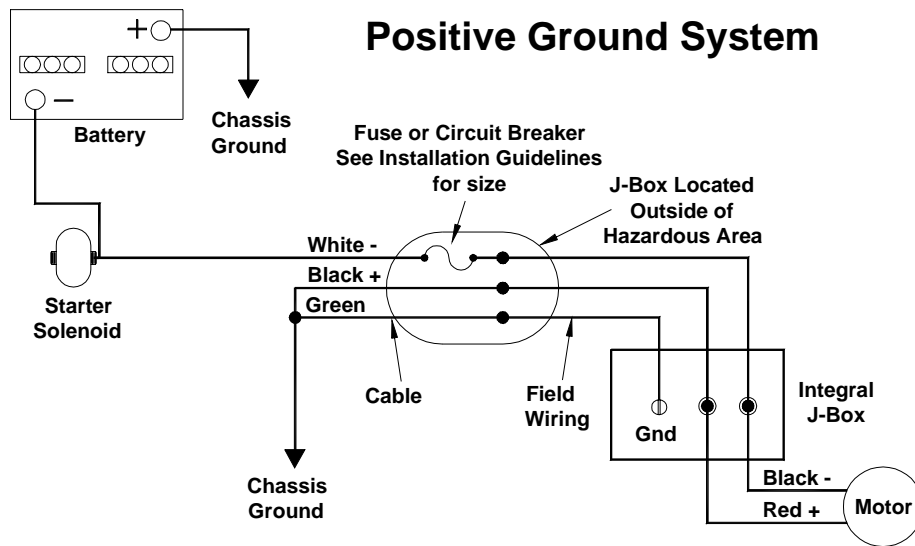
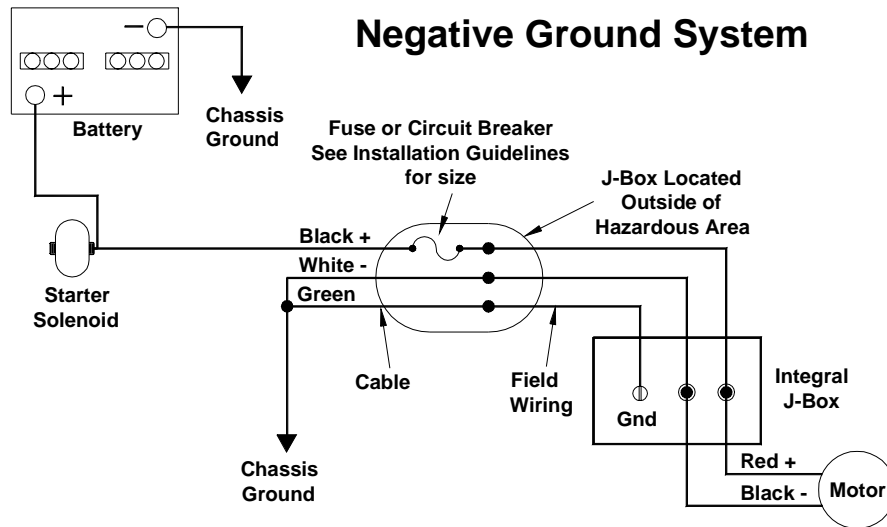

## **OPERATION**

**CAUTION**

**Be sure the electrical connection polarity is correct or damage may result to the pump.**

### **Start Motor**

Remove the nozzle from the nozzle boot and push down the switch shaft assembly.

### **Stop Motor**

Pull up the switch shaft assembly. Place the nozzle back in the nozzle boot.

**WARNING**

**Do not use an additional line valve or foot valve in the suction line.**

## Section 3

---

# MAINTENANCE AND TROUBLESHOOTING

---

### DISASSEMBLY OF MOTOR

**NOTE:** *To retain validity of the Underwriter's Laboratories (UL) Listing, all motors must be factory repaired or repaired by a firm with an approved UL procedure for the repair of explosion-proof motors.*

To disassemble the motor assembly, remove the two hex bolts and then remove the end cap and the field ring assembly. Note orientation of field ring assembly for proper reassembly.

To replace the brushes, remove the end cap and the field ring assembly. When you remove the terminal nuts and the brush retainer, the brushes are pulled up and out of the brush holder.

To remove on/off switch for replacement, remove silicone sealant from hole in side of motor housing. Next, remove the flush-installed drive lock pin (item 4 on page 4-5). This pin prevents the set screw (item 20 on page 4-3) from coming loose. After the pin is removed, remove the set screw. Then you can remove the on/off switch (item 1, page 4-5). Install new switch, set screw, and pin in reverse order.

### DISASSEMBLY OF PUMP

**NOTE:** *Numbers in parentheses correspond to the numbers shown on the parts illustration and parts list in Section 4.*

All working parts of the pump are accessible under clearly marked cover plates. Pump may contain product, so be prepared to catch product in an appropriate container when removing any cover.

Remove pump cover screws and remove cover plate (2) and square ring (3). Note orientation of rotor (5) and of vanes (38) in rotor slots. Remove key (4) and withdraw rotor and vanes from pump block (13). Since rotor is spring loaded, make sure washer (7) and spring (8) remain on pump shaft. Insert new rotor and replace vanes so that trailing edge slopes away from direction of pump rotation (counterclockwise). Reinstall key in shaft slot and rotor keyway. Check pump cover for scoring (if scored, replace). Replace square ring (3) and while holding rotor in against spring tension, slide cover over opening and tighten screws.

To replace shaft seal, remove rotor and vanes as above. Slide spring (8) and both washers (7) off shaft. O-ring (9) will act as a brake to resist removal of brass, rotating seal ring (10). To overcome this resistance, lightly grasp brass ring with pliers and pull at the same time turning shaft back and forth with the flat blade of a screwdriver in the keyslot in the end of the shaft. Remove O-ring from brass ring and spread some grease over machined surface of ring; reinsert brass ring over shaft and press greased surface against carbon, floating seal ring (11). The carbon ring can now be withdrawn stuck to the brass ring. Do not break up the carbon ring to remove it, since some of the pieces may get lost in the pump casting and cause the rotor or measuring chamber to jam later in service. Use a bent wire as a button-hook to hook and withdraw O-ring (12) from recess in back of pump cavity. Install new seal group (6) in reverse order. Make sure recess in back of pump cavity is clean and that O-ring (12) is firmly seated and not twisted in this recess.

**NOTE** *It is critical that the seal part mating surfaces remain clean and dry. Do not touch or allow oil of any type to contaminate the carbon or brass mating surfaces. If the seal inadvertently becomes contaminated, both mating surfaces must be carefully cleaned with a lint-free cloth and methyl alcohol.*

The bypass valve (31) is preset to provide maximum performance without overloading the motor and can be withdrawn by removing the bypass cover plate (33). When reassembling, make sure the holed end of the tube (34) and bullet-shaped nose of the valve (31) are inserted toward the pump.

The check valve is attached to the check valve cover (28) and will come out when the cover is removed. If you can hear the product in the suction line running back into the storage tank when this assembly (22) is removed, the check valve is holding and keeping the pump primed. When reassembling, make sure the rubber valve disc is facing down toward the valve seat.

**TROUBLESHOOTING CHART**

<b>Possible Cause</b>	<b>Checks</b>	<b>Corrective Action</b>
Will not start	Open circuit in the electrical service line.	Check breaker or fuse.
	Open circuit or short circuit in the armature winding.	Replace armature.
	Worn brushes and/or annealed brush springs.	Replace brushes.
Starts, but heats rapidly or runs too hot	Armature winding short circuited or grounded.	Check breaker or fuse.
Sluggish, sparks severely at brushes	High mica between the commutator bars.	Clean commutator.
	Worn brushes and/or annealed brush springs.	Replace brushes.
	Open circuit or short circuit in the armature winding.	Replace armature.
	Oil-soaked brushes.	Replace brushes.
Abnormally high speed, sparks severely at the brushes	Oil-soaked brushes.	Replace brushes.
Reduction in power, motor gets too hot	Open circuit or short circuit in the armature winding.	Replace armature.
	Sticky or tight bearings.	Replace bearings.
	Interference between the stationary or rotating members.	Locate interference.
	Excess carbon build-up at brush holder.	Clean brush holder.
Motor will not stop when switch is in OFF position	Faulty switch.	Replace switch.
Jerky operation, severe vibration	High mica between the commutator bars.	Clean commutator.
	Worn brushes and/or annealed brush springs.	Replace brushes.
	Open circuit or short circuit in the armature winding.	Replace armature.
	Shorted or grounded armature winding.	Replace armature.

(continued)

<b>Possible Cause</b>	<b>Checks</b>	<b>Corrective Action</b>
Pump fails to prime	<p>Leak at the suction pipe to pump connection.</p> <p>No liquid in the tank or the suction stub is not submersed in the liquid.</p> <p>By-pass valve leaking or stuck open.</p> <p>Nozzle is not open to allow the discharge of air in the hose.</p>	<p>Tighten connection.</p> <p>Correct condition.</p> <p>Replace bypass valve.</p> <p>Open nozzle.</p>
Motor speed is too slow.	Weak battery or bad motor.	Charge battery or replace pump.

## *Section 4*

---

# **PARTS**

---

This manual lists parts information for the Model 617 and 620 pump. Using part numbers when ordering will expedite your order and reduce the possibility of the wrong parts being shipped. When ordering replacement parts, be sure to give the complete name and part number as shown in the appropriate parts lists. It is also helpful to supply the serial number of the equipment. Screws, nuts, washers and pins are not furnished with parts except when specified in the list as being included.

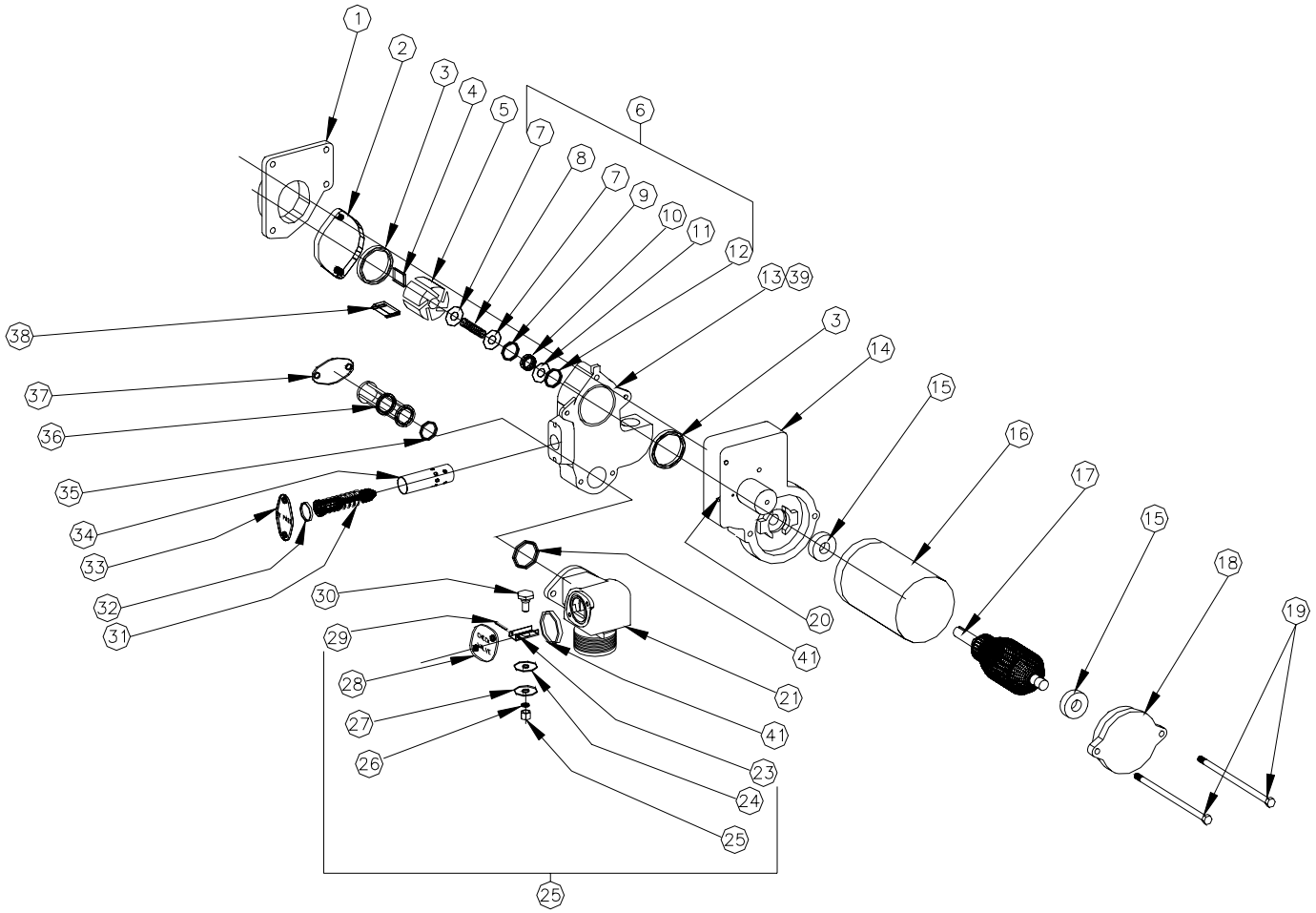

## GENERAL ASSEMBLY

Item	Part No.	Description
1	003819	Switch Cap
2	003490	Pump Cover
3	049004	Square Cut Ring
4	031285	Key
5	051475	Rotor
6	054026	Seal Group (includes items 7-12)
7	*067210	Washer
8	*057955	Seal Spring
9	*048941	O-ring
10	*049510	Rotating Sealing Ring
11	*048820	Floating Seal Ring
12	*048971	O-ring
13	003210	Pump Block
14	003813	Motor Housing
15	011869	Bearing
16	037405	Field Assy.
17	010907	Armature 12VDC
	010908	Armature 24VDC
18	003814	End Cap
19	012905	Hex Bolt, 5/16-18 X 6 1/2
20	053170	Set Screw, 1/4-20 X 1/2" <i>(NOTE: Covered with silicone to prevent water entry.)</i>
21	003065	Base
22	066655	Check Valve Assy. (includes items 23 to 29)
23	*029155	Valve Guide
24	*068680	Washer
25	*038980	Hex Jam Nut
26	*068650	Washer
27	*024356	Valve Disk
28	*022271	Check Valve Cover Assy.
29	*042370	Cotter Pin
30	062620	Valve Stem
31	062338	Bypass Stem Assy.
32	049001	Square Ring
33	022315	By-pass Cover
34	065725	Tube, By-pass Valve
35	049002	Square Ring
36	063266	Strainer, 30 mesh
37	022900	Strainer Cover
38	067030	Vane
39	052976	Ground Screw (Not Shown)
40	067466	Shim Washer
41	049003	Square Cut Ring

\* Indicates part is a sub-part of preceding part.

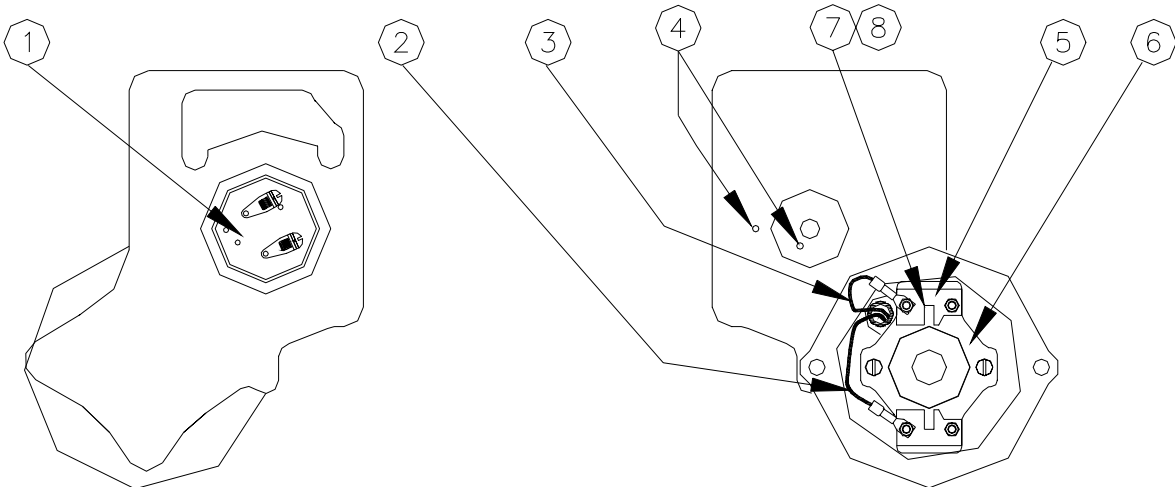

---

## **PUMP AND MOTOR ASSEMBLY**

1	033759	Switch, On/Off
2	014161	Lead Assy., (+)
	014160	Lead Assy., (-) (Not Shown)
3	014162	Lead Assy.
4	042580	Drive Lock Pin (2 required)
5	015848	Brush Retainer
6	015845	Brush Holder
7	015846	Brush (Not Shown, 2 required)
8	057867	Spring (Not Shown, 2 required)

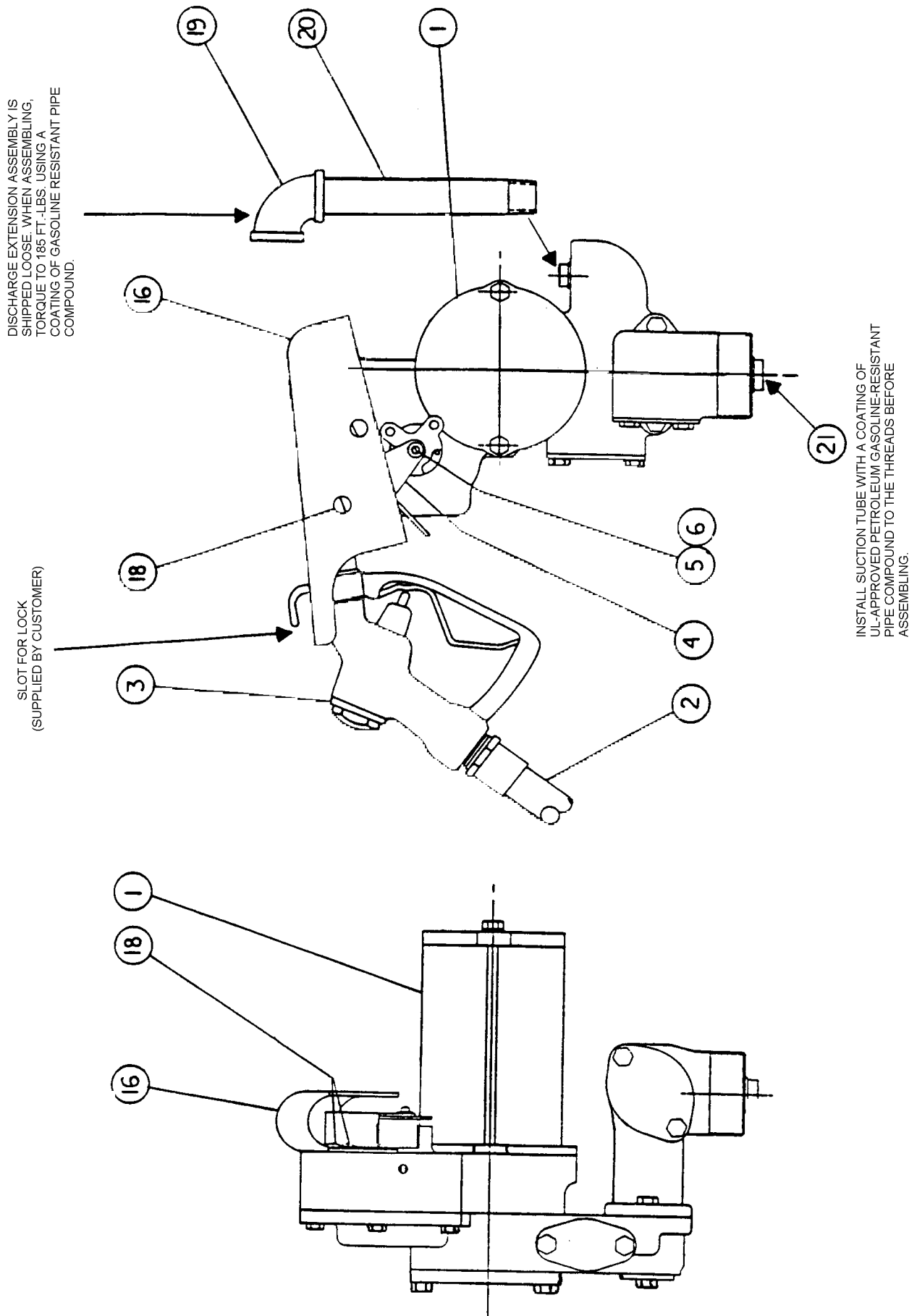

## GENERAL ASSEMBLY - EXTERIOR

Item	Part No.	Description
1		Pump & Motor Assembly, 12VDC (Not sold separately, requires replacement of pump) Pump & Motor Assembly, 24VDC (Not sold separately, requires replacement of pump)
2	030430	Hose, 1" X 12'
3	038509	Nozzle, 1" NPT, Leaded
	038469	Nozzle, 1" NPT, Unleaded
4	064307	Switch Lever Assembly
5	052765	RHMS, #8-32 X 5/16
6	C01171	Lockwasher, #8
11	021857	Cable Connector, Old Style (Not Shown)
	020706	Cable Connector, New Style (Not Shown)
		<i>NOTE: Design change was made for pump housing. Pumps older than serial number 403095 must use cable 021857.</i>
12	021813	Wire Connector (Not Shown)
13	022907	Power Cord, 15 ft. (Not Shown)
14	020826	Battery Clip, positive (Not Shown)
15	020825	Battery Clip, negative (Not Shown)
16	003807	Nozzle Boot
18	053903	Fl. Hd. Machine Screw, 1/4-20 X 1/2"
19		<b>1" Discharge Units</b>
	024925	Elbow, 3/4" x 1" x 90 reduc.
		<b>1" Discharge Units w/Vacuum Breaker</b>
	064796	Tee, 1", Optional, Not Shown
	017270	Bushing, 3/4" x 1" Reduc., Optional, Not Shown
	017286	Hex Bushing, 3/4" x 1/8", Optional, Not Shown
	066570	Vacuum Breaker, Optional, Not Shown
20	044089	Pipe Nipple, 3/4" X 6 7/8"
21	064895	Suction Tube, 1" NPT

## OPTIONS (NOT SHOWN)

035606	Meter, Model 3460-4J, US Gas (customer-installed)
033147	Meter, Model 3460-4J, US Diesel (customer-installed)
035607	Meter, Model 3460-4J, Liter Gas (customer-installed)
033142	Meter, Model 3460-4J, Liter Diesel (customer-installed)
033063	Meter Repair Kit
038519	Automatic nozzle, std. flow, unleaded
038520	Automatic nozzle, std. flow, leaded

# WARRANTY

## General Statements:

Gasboy International LLC warrants all new equipment manufactured by Gasboy against defective material and/or workmanship, for the warranty period specified below, when the equipment is installed in accordance with specifications prepared by Gasboy.

This warranty does not cover damage caused by accident, abuse, Acts of God, lack of surveillance of automatic recording systems, negligence, mis-application, faulty installation, improper or unauthorized maintenance, installation or use in violation of product manuals, instructions, or warnings. Under no circumstance shall Gasboy be liable for any indirect, special, or consequential damages, losses, or expenses to include, but not limited to, loss of product, loss of profits, litigation fees, or the use, or inability to use, our product for any for any purpose whatsoever.

Parts Only - During the warranty period, Gasboy will, at its option, repair or replace defective parts returned transportation prepaid to its factory.

On-Site Labor Included - Gasboy will also provide, within the Continental United States and during the warranty period, the services of an Authorized Service Representative (ASR) for on-site repair or replacement of defective parts.

Replacement Parts - Any system components that are not part of the original system order, including Island Card Readers, Pump Control Units, etc., are considered replacement parts.

Equipment	Term	Coverage
Commercial Pumps and Dispensers Full-Cabinet Consumer Pumps	One year from date of installation or 18 mos. from date of Gasboy International's invoice to the purchaser, whichever comes first.	Parts and Labor.
Small Transfer Pumps, Meters, Pressure Regulators	One year from date of installation or 18 mos. from date of Gasboy International's invoice to the purchaser, whichever comes first. - Excepting the Model 2020 Hand Pump, which has a 90-day warranty from date of GASBOY International's invoice.	Parts Only.
Keytrol	One year from date of installation or 18 mos. from date of Gasboy International's invoice to the purchaser, whichever comes first.	Parts and Labor.
Fuel Management Systems: - CFN/ Profit Point - Series 1000/Fleetkey - TopKAT - Fuel Point Readers (sold with new systems)	One year from date of start-up or 15 mos. from date of Gasboy International's invoice to the purchaser, whichever comes first. - The basic warranty only applies to systems which have been started up by a Gasboy Authorized Service Representative (ASR).	Parts and Labor.
Additional Fuel Point Items: - Fuel Point Readers sold for retrofitting existing systems. - Fuel Point vehicle and dispenser components.	One year from date of start-up or 15 mos. from date of Gasboy International's invoice to the purchaser, whichever comes first.	Parts Only.
Encoders, Embossers, Modems, CRTs, and Logger Printers	Purchased with Fuel Management System (Encoders, Embossers only): 90 days from the date of start-up by a Gasboy ASR, or 180 days from date of Gasboy International's invoice, whichever occurs first.  Purchased with Fuel Management System (Modems, CRTs, and Logger Printers only): Matches system warranty.  Purchased Separately: 90 days from date of Gasboy International's invoice to the purchaser.	Purchased with System (Encoders, Embossers only): Parts only.  Purchased with System (Modems, CRTs, Logger Printers only): Matches system warranty.  Purchased Separately: Parts Only.
Air Diaphragm Pumps	Three years from date of purchase (for full warranty description, see Price List).	Parts Only.
Items not manufactured by Gasboy (ex. automatic nozzles, hoses, swivels, etc.)	Not warranted by Gasboy International (consult original manufacturer's warranty).	Not Applicable.
Replacement Parts	One year from date of Gasboy International's invoice to the purchaser.	Parts Only.

To the extent permitted by law, this warranty is made in lieu of all other warranties, expressed or implied, including warranties of freedom from patent infringement, or merchantability, or fitness for a particular purpose, or arising from a course of dealing or usage of trade. No one is authorized to vary the terms of the warranty nor may anyone make any warranty of representation, or assume any liability other than that herein stated, in connection with the sale described herein. The acceptance of any order by Gasboy International is expressly made subject to the purchaser's agreement to these conditions.



**GASBOY INTERNATIONAL LLC**

P.O. Box 309, Lansdale, PA 19446 ● (800) 444-5579 ● FAX: (800) 444-5569 ● www.gasboy.com